

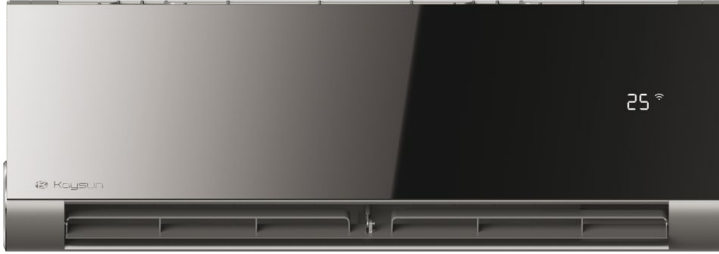

Onnix Multisystem

PRODUCT SHEET



KID-05 S
Standard controller

Product certified by: 



FEATURES

Model	KAY-D 26 DR9	KAY-D 35 DR9
Cooling capacity	2,64 kW	3,52 kW
Heating capacity	2,93 kW	3,82 kW
Airflow	384/478/558 m ³ /h	384/478/558 m ³ /h
Sound pressure	24 dB(A)	24 dB(A)
Power supply	220-240 V / 1 / 50 Hz	
Communication wiring	(3+T)x2,50 mm ²	
Refrigerating pipes	Ø1/4" / Ø3/8"	Ø1/4" / Ø3/8"

WIRING DIAGRAM

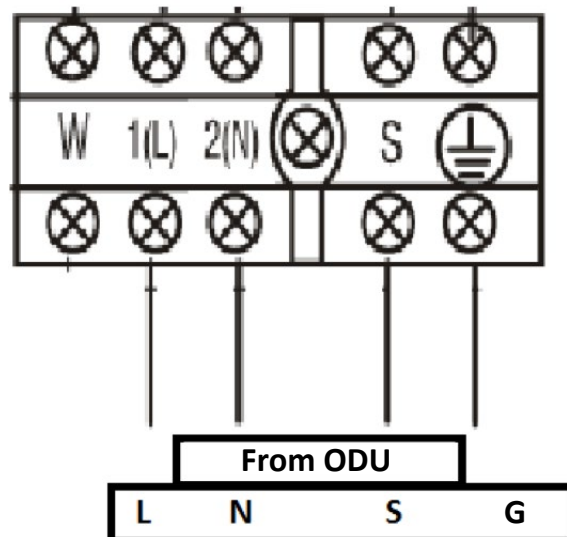

NOTES:
(1) The data and specifications present in this sheet may vary without notice.
(2) The images on this sheet are indicative and may be different from the final machine.

DIMENSIONS & WEIGHT OF INDOOR UNIT

Model	Weight	W	H	D
KAY-D 26 DR9	10,50 kg	897 mm	312 mm	182 mm
KAY-D 35 DR9	10,50 kg	897 mm	312 mm	182 mm

